

ULTRASONIC FLOW SENSOR IFX

Serie 01 - Class 2 - MI004

Technical specification - ultrasonic flow sensor IFX-M4-01

Dimensions of flow sensor **IFX-M4-01**, flow rates, connection type and pressure losses are presented in this table:

Connection type	Overall length mm	Flow-rate m ³ /h			Pressure losses Δq_p at $q=q_p$, MPa, not more, than
		q_i	q_p	q_s	
G 1¼ (DN25)	260	0,035	3,5	7	0,004
G 1¼ (DN32)	260	0,06	6	12	0,01
G2 (DN40)	300	0,1	10	20	0,01
DN50	270	0,15	15	30	0,012
DN65	300	0,25	25	50	0,02
DN80	350	0,4	40	80	0,018
DN100	350	0,6	60	120	0,018

Table of minimum settable pulse value depending on the nominal flow rate and sensor, that can be required as option:

DN	25	32	40	50	65	80	100
Permanent flow q_p , m ³ /h	3,5	6	10	15	25	40	60
Pulse value, liter/pulse	0,02	0,02	0,05	0,05	0,2	0,2	0,5

The factory default is 10 liters per pulse for all DN.
Different setting upon request.

General conditions:

Ambient temperature	5 °C to 55 °C
Fluid temperature	0 °C to 130 °C
Max permissible pressure	< 1,6 MPa
Protection class	IP65 (IP67 on request)



Nominal diameter DN, mm	25	32	40	50	65	80	100
Weight, less than, kg	3,0	3,0	10,0	10,0	14,0	15,0	19,0

- The flow sensor meets the requirements according to 89/336/ EEC, EN50082-2, EN50081-2.
- Flowmeter may be installed both vertically and horizontally in pipelines. Vertical mounting is allowed only if flow direction in the pipeline is upwards. Flow direction is marked with arrow symbol on the body of the flow sensor.
- MID approval available.
- Easy connection to ISO^{NRG} ML311 serie, or another BTU meter (Please see ISO^{NRG} specifications separately)

ISOFLUX IFX - How to order

MID	— [0=EN1434 conform 4=MI004 marked
VERSION	— [01=Sensor (Pulses) 03=Small (DN15-50) 04=Wide (DN25-100)
INSTALLATION	— [1=Forward 2=Return side
APPLICATION	— [A=Heating B=Heating/Cooling
DN/FlowRATE	— [10=DN15/0,6 11=DN15/1 15=DN15/1,5 20=DN20/2,5 25=DN25/3,5 32=DN25/6 40=DN40/10 50=DN50/15 65=DN65/25 80=DN80/40 100=DN100/60 150=DN150/140 (no MID) 200=DN200/550 (no MID)
SUPPLY	— [A=Battery 12y (version 01/03) 2=External (version 03/04) 3=Main (version 04)
OUTPUT	— [1=Pulse (version 01) 2=M-bus (version 03/04) 3=RS232/485 (version 04) 4=M-bus/RS232/Current (version 04) 5=Wireless (version 03)
CABLE	— [0=No cable 1=1,5 mt (std. version 03) 3=3 mt (std. version 01/04) 5=5 mt 10=10 mt 15=15 mt 20=20 mt
OPTION	— [0=No interface kit 2=Optical adapter version 03 3=Reader SW/LOG 4=Optical ad. for terminal 5=Handheld terminal 6=Cable set-up version 01 to ISO ^{NRG}



ISOIL INDUSTRIA
Cinisello Balsamo - Milano (Italy)
Via Fratelli Gracchi, 27
tel. +39 0266027.1 - fax +39 026123202
Italy: www.isoil.it - isothermic@isoil.it
International: www.isoil.com - sales@isoil.it

ISOFLUX™

The ultrasonic flow solutions



HEATING AND COOLING FOR BUILDING AUTOMATION

MID004 CERTIFIED CONFORMITY EN1434

ISOFLUX 

The ultrasonic flow solutions

RESIDENTIAL ENERGY METER IFX Serie 03 - All in one

Application

Ultrasonic heating and cooling energy meter **IFX-M4-03** is designed to measure and to record data in two separate registers.

It can be used for commercial metering of energy consumption for local or district heating systems: in domestic housing, office buildings, energy plants and similar projects.

Main features and advantages

- List of displayed parameters can be set by the user.
- Two universal pulse inputs / outputs available - can be used to connect additional pulse sources (for example - water meters), or as pulse outputs (for energy, volume values etc.).
- M-Bus, Current interface modules or wireless radio readout modules available.
- Tariff function available.
- Programmable monthly and yearly set days.
- Hourly, daily and monthly consumption values are stored in the internal data logger.
- Daily and monthly extreme (min/max) values with time stamps are recorded.
- Flow direction indication.
- The calculator can be mounted on the flow sensor or in other convenient location (on the rail, inside a hermetic enclosure or on the wall).

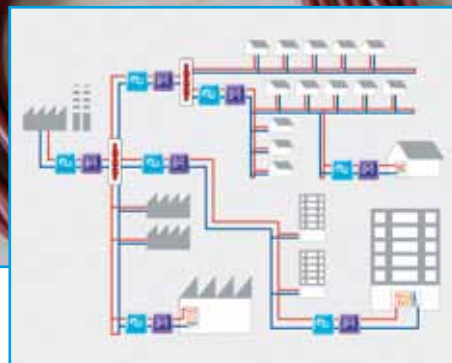
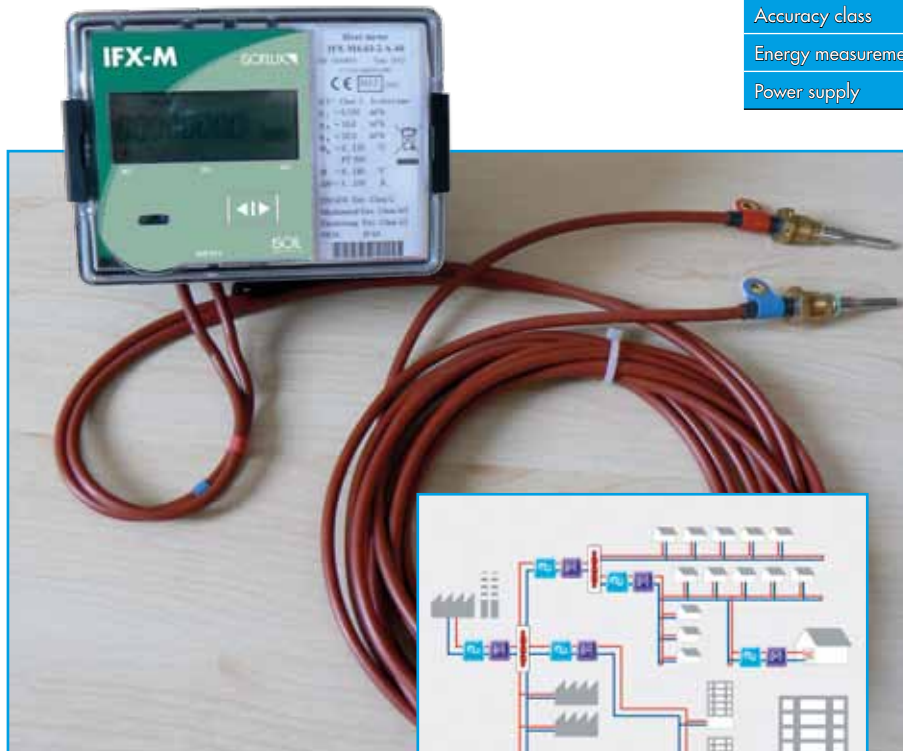

Facilities (cities heating/refrigeration)

Flow measurement

Flow measurement limits, mounting length and connection type:

Connection type	Mounting length, mm	q_r , m ³ /h	q_p , m ³ /h	q_v , m ³ /h
G 3/4"	110	0,006	0,6	1,2
G 3/4"	110	0,015	1,5	3,0
G1"	130	0,025	2,5	5,0
G1 1/4"	260	0,035	3,5	7,0
G1 1/4"	260	0,06	6,0	12,0
G2"	300	0,100	10,0	20,0
DN50	270	0,15	15,0	30,0

Fluid temperature range 5 °C ... 130 °C, for $q_p \leq 2,5$ m³/h
10 °C ... 130 °C, for $q_p \leq 3,5$ m³/h

Maximum permissible pressure 1,6 MPa

Temperature measurement

Fluid temperature 0 °C ... 180 °C

Temp. difference measurement limits 2 ... 150 K or 3 ... 150 K

Type of temperature sensors Pt500 DS ($q_p \leq 6$ m³/h) or PL

Connection scheme – two-wire, cable length up to 5 m

Internal data logger capacity up to 960 hours for hourly records
up to 1116 days for daily records
up to 36 months for monthly records

External dimensions of the calculator 117 x 44 x 90 mm

Protection class IP65 (IP67 on request)

Ambient temperature 5 °C to 55 °C

Communication interfaces

Optical communication interfaces integrated, according to EN 61107 (IEC 1107)

Available types of plug-in interface modules M-bus; 2 pulse outputs; Wireless 868 MHz

Accuracy class 2 (according to EN1434)

Energy measurement units kWh, MWh, GJ, Gcal

Power supply internal battery (lifetime not less than 11 years)

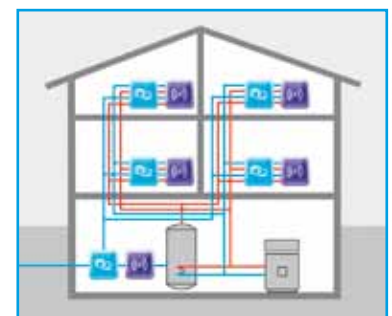

Commercial (offices, industrial, building automation)

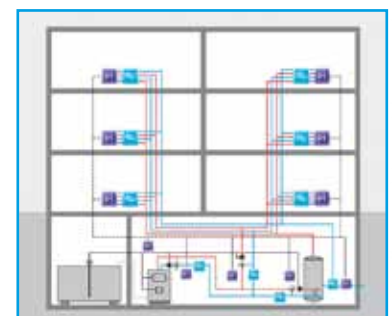

Domestic (residential houses, condominium)

ENERGY METER IFX Serie 04 - All in one

Application

Ultrasonic energy meter **IFX-M4-04** can be used for measurement of consumed heat energy and heating or cooling medium (or other fluid quantity) in closed or open loop heating and water consumption systems.

Main features and advantages

- Energy meter **IFX-M4-04** can be used for heat and flow measurements in closed or open loop heat supply systems.
- Two flow measurement channels.
- Two pressure measurement channels.
- Two pulse inputs for additional flow sensors.
- Pre-programmed or measured pressure values may be used for energy calculation.
- Cold water temperature for open loop application can be measured, or pre-programmed temperature value can be used.
- Optional integrated regulation or alarm function.
- Internal data logger: for daily records – last 33 months, for hourly records – last 3,5 months.
- Power supply – from internal battery of more than 12 years or 230 V AC power source.
- Possibility to choose the list of indicated parameters.

Parameter	Value
Input pulse value	programmable
Input pulse type	active or passive
High voltage level for active pulses	2,5 ... 3,7 V
Low voltage level for active pulses	0 ... 0,7 V
Input resistance, when powered from internal battery	2 MΩ
Input resistance, when powered from AC source	10 kΩ

Available versions DN150 and DN200 flanged, non MID.

Connection type	Overall length mm	Flow-rate m ³ /h			Pressure losses Δq _p at q=q _p , MPa, not more, than
		q _i	q _p	q _s	
G 1¼ (DN25)	260	0,035	3,5	7	0,004
G 1½ (DN32)	260	0,06	6	12	0,01
G2 (DN40)	300	0,1	10	20	0,01
DN50	270	0,15	15	30	0,012
DN65	300	0,25	25	50	0,02
DN80	350	0,4	40	80	0,018
DN100	350	0,6	60	120	0,018



Temperature measurement	
Number of measurement channels	1, 2 or 3
Temperature measurement limits	0 °C ... 180 °C
Temp. difference measurement limits	2 K ... 150 K
Type of temperature sensors (2 or 4 wires)	Pt500 (W1,385), 500II (W1,391) Pt1000 (W1,385), 1000II (W1,391)
Cable length between the calculator and each of the sensors: – four-wire connection scheme – two-wire connection scheme	10 m; 25 m; 50 m; 100 m 2,5 m; 5 m
Display resolutions for temperature and temperature difference	0,01 °C
Pressure measurement	
Number of pressure measurement channels	up to 2
Input current limits (programmable)	0 ... 5 mA, 0 ... 20 mA, 4 ... 20 mA
Lower/Upper pressure measurement limits (programmable)	0 ... 2500 kPa 100 ... 2500 kPa
Relative normalized pressure measurement error	not more than ±0,25% from the upper pressure measurement limit
Communication interfaces	
Optical communication interfaces	integrated, according to EN 61107 (IEC 1107)
Available types of plug-in interface modules	M-bus; M-bus/CL/RS232 and 2 pulse outputs; M-bus/CL/RS232 and 2 current outputs; RS232; RS485; Wireless 868 MHz
Power supply options	
Internal battery	3,6 V, battery lifetime - not less than 10 years
AC source supply	230 V, AC 50 Hz
General conditions	
Ambient temperature for the calculator	5 °C ... 55 °C
Environment class	C according to N1434
Protection class for the calculator	IP65
External dimensions of the calculator	159 × 142 × 52 mm